

## GENERAL INSTALLATION INFORMATION

To ensure maximum performance from your bath fixture, please read and follow the instructions and cautions. Carefully inspect the new fixture for any shipping damage. If any damage is found, report it to your vendor immediately. Under no circumstances should a damaged fixture be installed. The manufacturer and its distributor are not responsible for removal or re-installation costs if a replacement fixture is necessary due to installation of a damaged fixture. Do not make modifications to the bath fixture. This could adversely affect the safety and performance of the fixture and void the warranty. Any failure to comply with the installation instructions and cautions may void the warranty.

Note. Do Not remove the Medallion Identification Number. Doing so may affect the warranty. This number may be found above on the lower part of the apron/skirt.

## Items Included

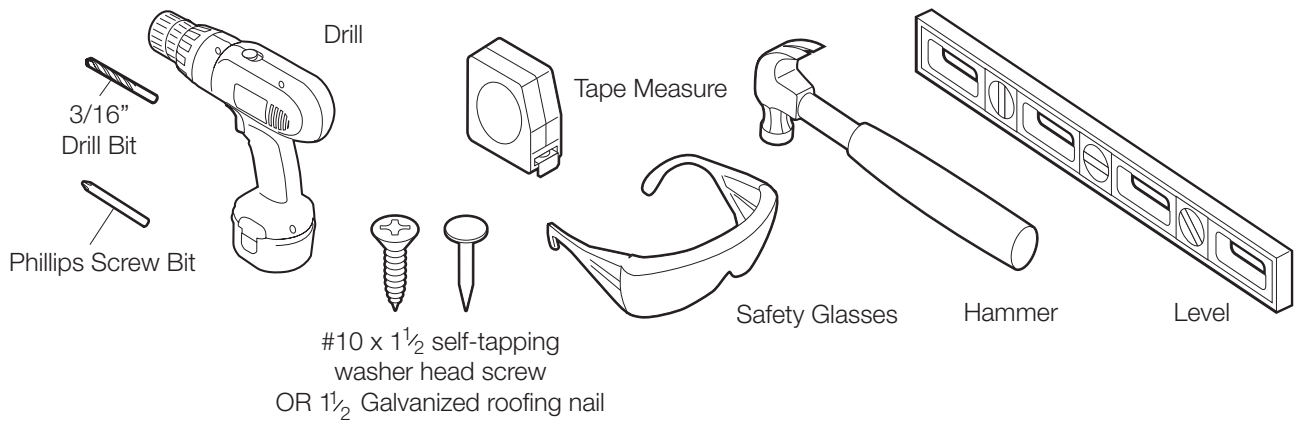
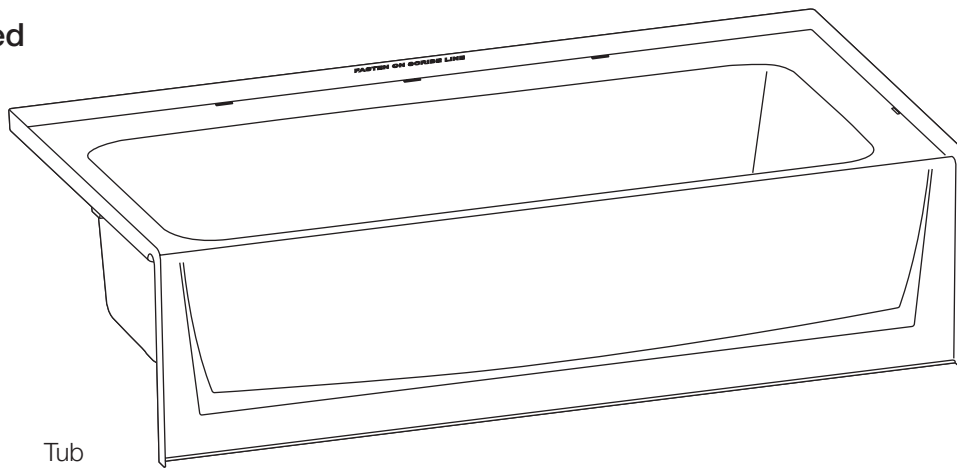

**PLEASE READ ALL INSTALLATION INSTRUCTIONS COMPLETELY BEFORE BEGINNING THE INSTALLATION.**

## PRE-INSTALLATION PLANNING

1. Review job print and rough-in dimensions, verify all key dimensions against actual job conditions. **MUST ENSURE ROUGH DIMENSIONS ARE PROPER AND SQUARE.**
2. Locate studs as required and in remodeling, if necessary, add studs at each end to provide a vertical nailing flange surface for the stud nailing flanges of the fixture.
3. Make sure framed-in framing pocket is of proper size, square and plumb. Check floor for level. Some shimming between the stud frame and fixture may be required.
4. **DO NOT** install the product over open floor joists. Product should not require any additional support if the sub floor is square and level with framing. Shimming or foundation material may be required for additional support, if sub floor is uneven.
5. If fire rated framing pocket is required, approved finish material must be in place prior to unit installation to meet fire safety requirements of local building code and/or FHA/HUD Minimum Property Standards. **NOTE:** Finished framing pocket must have interior dimensions shown on rough-in diagram to permit installation of the unit.
6. Foundation material is not required.
7. Tubs require a 6" x 12" (150mm x 305mm) floor opening for the 1½" (40mm) drain, waste and overflow (DWO) kit. (see diagram 1). **NOTE:** Be sure floor opening location matches left-hand or right-hand bath fixture drain location.
8. To ensure proper installation of the fixture, all local plumbing and building codes must be observed. Local building codes vary by location and you are responsible for insuring plumbing is complete and to code.
9. To avoid obstruction, make sure that supply lines and valve plumbing do not project into framing pocket during the installation process. Also, drain pipe must not project above floor level prior to installation.
10. On inside of plumbing wet wall of unit, note location of supply elbow and mixer valve.  
**Tub Mounted Fittings:** If mounting fitting on tub, from stable reference points ( back wall studs, floor), measure the locations of spout and valves. Note measurements: **Tub Filler:** \_\_\_\_\_ **Valve:** \_\_\_\_\_
11. To prevent scuffing while installing unit, cover the floor of the unit with a piece of cardboard or other protective material.
12. Fasteners for: Wood framing - 1½" galvanized roofing nails or #10 x 1" self tapping washer head screws.  
Concrete or block walls - 1" concrete nails and nailing tool.  
Steel studs (18 ga.) - drill flanges and studs with 5/32" carbide bit and use #12 x 1" sheet metal screws.  
**NOTE:** Always pre-drill no matter what fastener is to be used.
13. The slots on the horizontal surface near the nailing flange are used when installing the matching wall system. These slots can be covered with wall material during a tub only installation.

## INSTALLATION PROCEDURE

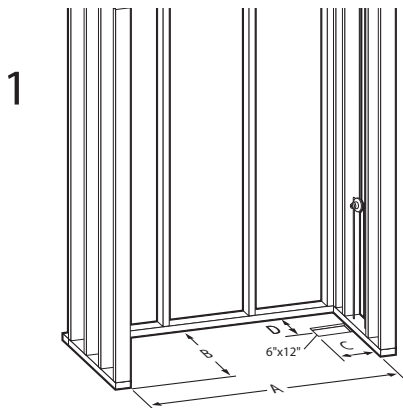

Model	A	B	C	D
VP6030CT/CTM	60"	31½"	2⅞"	14¼"
VP6030CTMIN/MM	60"	31½"	2¾"	14⅝"
VP6032CTMIN/MM	60"	33½"	2¾"	15¾"
VP6036CT/CTM	60"	37½"	2"	17⅜"
VP6042CT/CTM	60"	43½"	2"	20⅜"

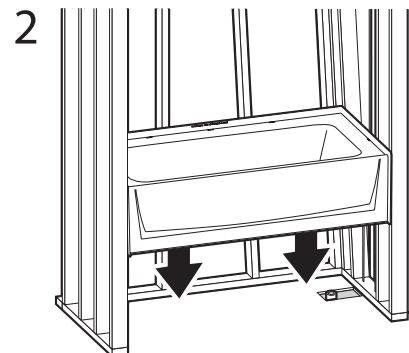

Check dimensions. **NOTE:** If you are adding additional accessories such as a grab bar-additional framing may be needed for support.

Lift and place the base into framing.

Pre-Install unit to ensure framing pocket is plumb, square and a level installation can be achieved (see steps 2 and 3). Adjust framing as needed-Shim where necessary.

## INSTALLATION PROCEDURE, CONT.

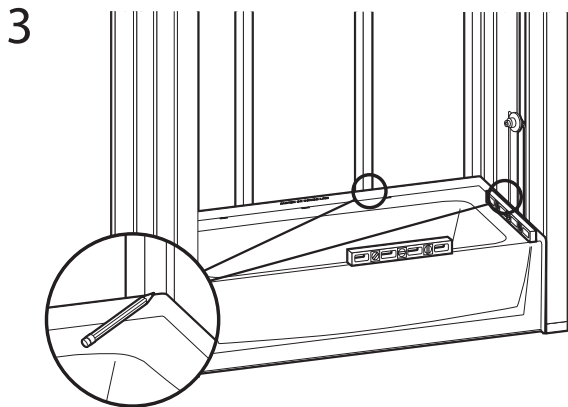

Level and mark all sides. Front apron should be firmly on the floor.

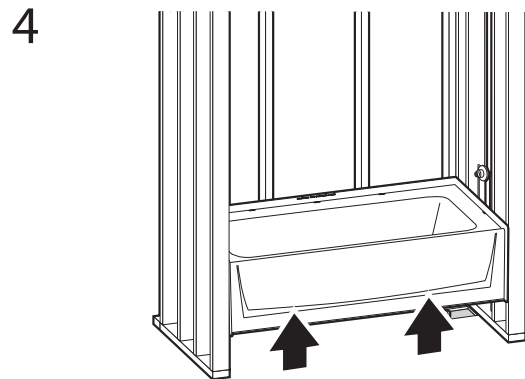

Remove tub.

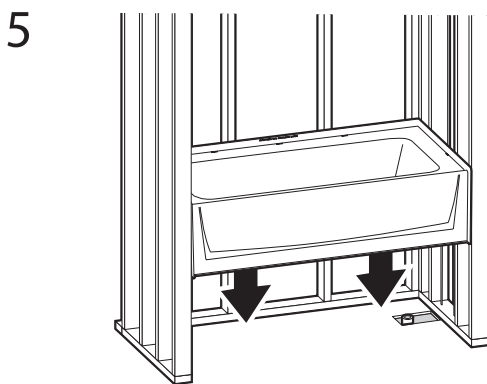

Install drain assembly per manufacturer's instructions. Place base into framing pocket.

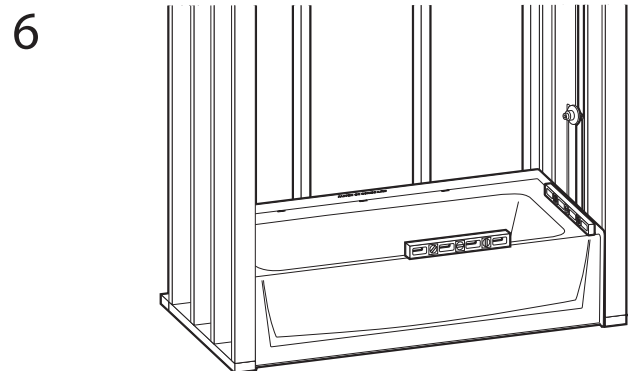

Level lengthwise and widthwise using a 3 ft. (915mm) level by shimming if necessary. The unit must be set level.

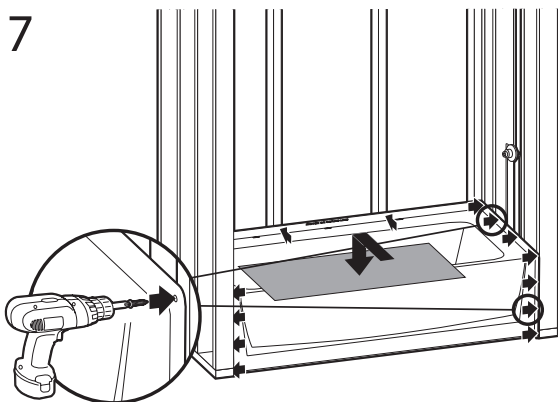

Pre-drill horizontal flanges along top of base section and fasten into each corresponding stud. Pre-drill both (vertical) side flanges and fasten to side studs. 8" (200mm) on center. Place cardboard to protect finish.

## CLEAN-UP

**CAUTION: Some cleaning products are not suitable for use. Read all labels carefully.** DO NOT USE if labels say heat, solvent based cleaning fluids, or “not suitable for use with fiberglass”.

**NOTE:** Do not remove warranty/maintenance adhered label, Warranty/User maintenance label must be left for occupant (Required by ANSIZ124).

1. To prevent staining, remove all debris before plumbing leak test. Drain and wipe clean immediately after the inspection process. Use sponge with warm water and liquid detergent. Rinse, drain and wipe clean. Do not use abrasive cleansers that might mar, dull or scratch the finish such as scouring powders, steel wool, metal scrapers, or sandpaper.
2. If drywall mud or plaster gets on your fixture, it may be carefully removed with a wooden scraper. Roofing tar or paints may be removed with rubbing alcohol or paint thinner. Lacquer thinner should never be used on the fixture.
3. Plaster and latex paint may be removed with warm water, liquid detergent and brittle brush or plastic scraper. Do not use metal scraper or utensil to remove plaster or paint from finish.
4. Dull areas and light scratches around the outer edges of the fixture can be restored to a high gloss by buffing with a soft cloth with white or cream-colored automotive rubbing compound, followed by the application of a coat of good quality white automotive polish (or similar) and buff with a soft cloth. DO NOT WAX standing surfaces of the unit bottom (this includes textured, slip resistant standing surfaces), which could result in a greater risk of slipping and personal injury.
5. Major gouges require professional repair.
6. See user maintenance instructions and label for more details.

## USER MAINTENANCE INSTRUCTIONS

**IMPORTANT! Use only recommended cleaners and procedures described herein. Use of other materials and methods may damage your bath fixture and void the warranty.**

1. For normal cleaning, never use abrasive cleaners such as scouring powders or pads, steel wool, scrapers, sandpaper or anything else that could scratch or dull the surface of your fixture. Use warm water and liquid detergents or non-abrasive cleansers, such as Soft Scrub Gel or Comet Gel. Read all labels carefully and DO NOT USE if they say “not suitable for use with fiberglass”.
2. To keep your bath fixture sparkling clean, apply a coat of good quality automotive paste wax or polish and buff to a high shine with a soft cloth or towel. Repeat every six months for easier cleaning and long lasting protection. DO NOT WAX standing surfaces of the unit bottom (this includes textured, slip resistant standing surfaces), which could result in a greater risk of slipping and personal injury.
3. To restore a scratched or dull unit, use an automotive polishing compound applied with a clean cotton rag. Rub scratches and dull areas vigorously. Wipe off residues. Follow with automotive wax treatment described above. DO NOT WAX standing surfaces of the unit bottom (this includes textured, slip resistant standing surfaces), which could result in a greater risk of slipping and personal injury.
4. To remove adhesive, try 3-M™ natural cleaner, De-Solv-it™ or similar materials. If residues remain, saturate a small white cotton rag with nail polish remover and rub vigorously until the adhesive dissolves and disappears. These solvents are highly flammable and must be used sparingly and with caution. Do not allow solvent to go down the drain. Make sure not to contact plastic drain grates or other synthetic materials.
5. Rubber mats: If you use a rubber “anti-skid” mat, make sure to remove it from the unit after each use to avoid harm to the surface finish.
6. Hard water: Water in certain regions, if not wiped up after bathing/showering, may cause fading of some fixture colors. This is a natural occurrence beyond the manufacturers control and the manufacturer is not responsible for any fading caused from hard water (see Warranty).

**CAUTION: When using any cleaning or polishing materials, make sure to read and follow all packaging instructions carefully. Wear rubber gloves at all times and avoid contact with eyes, skin, clothing, rugs and furnishings. Make sure all residues are rinsed off thoroughly.**

## WARRANTY

If a Swan product covered by this warranty is found to be defective in materials or workmanship, after inspection by an authorized Swan Corporation representative, we will repair or at our option, exchange the product for a similar model. This warranty extends for a designated period of time, so long as it remains in use in its original place of installation.

This warranty covers products installed in accordance with the Swan Corporation Installation Instructions, used as recommended and not damaged due to misuse, abuse, or improper installation. It does not apply to any seams or improper installation. It does not apply to any seams or changes made to the product by professional tradesman or fabricators.

The Swan Corporation's option to repair or exchange the products under this warranty does not cover any labor or other costs of removal or installation, nor shall the Swan Corporation be responsible for any other incidental or consequential damages attributable to a product defect or to the repair or exchange of a defective product.

### **Residential Limited Lifetime Warranty**

The warranty applies only to the original purchaser and installation of these products in residential applications. It does not apply to commercial applications.

### **Commercial 5-Year Limited Warranty**

The warranty applies only to the original purchaser and installation of these products in commercial applications.